

CORRIGÉ

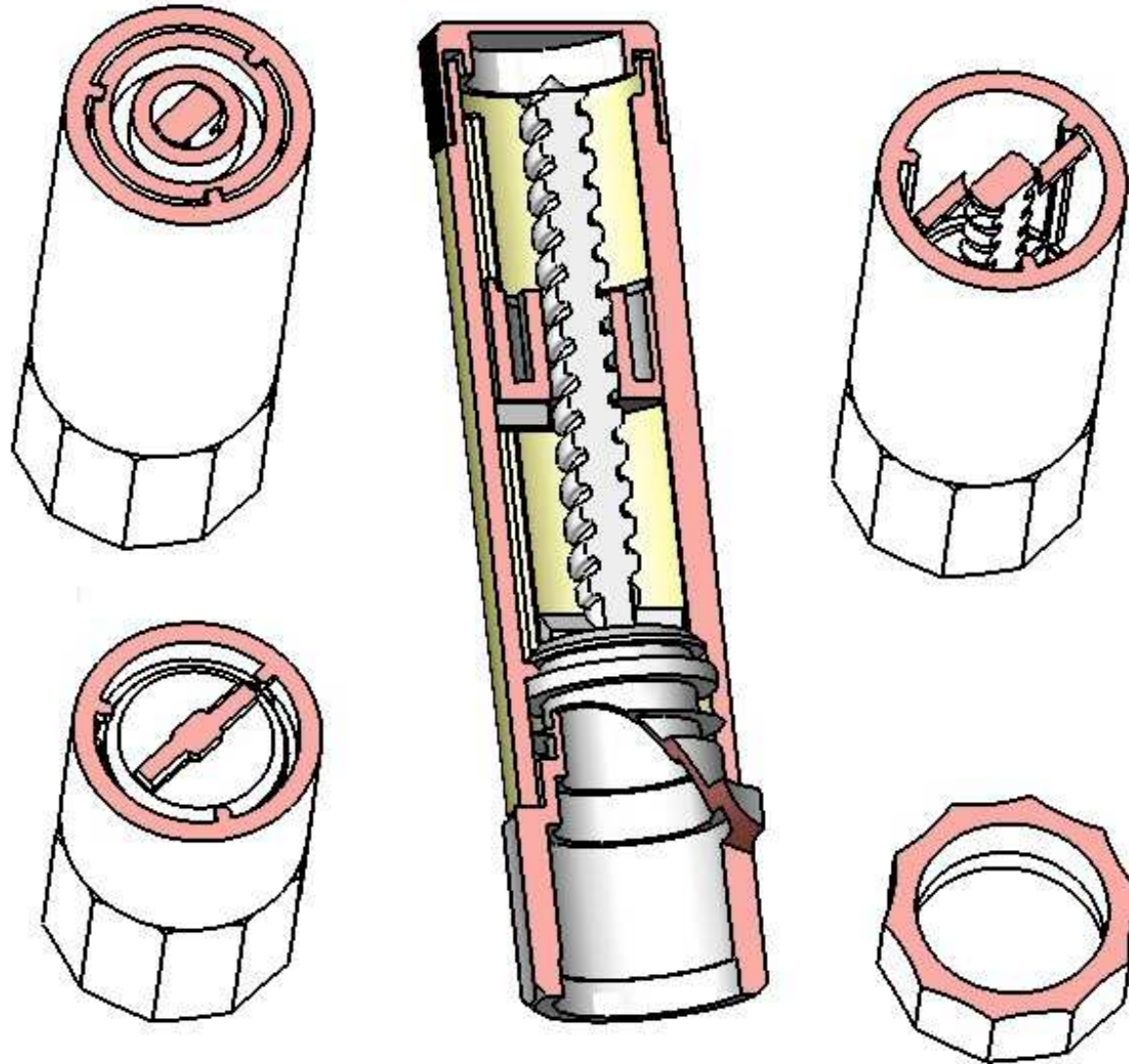

# Tube de colle

CORRIGÉ

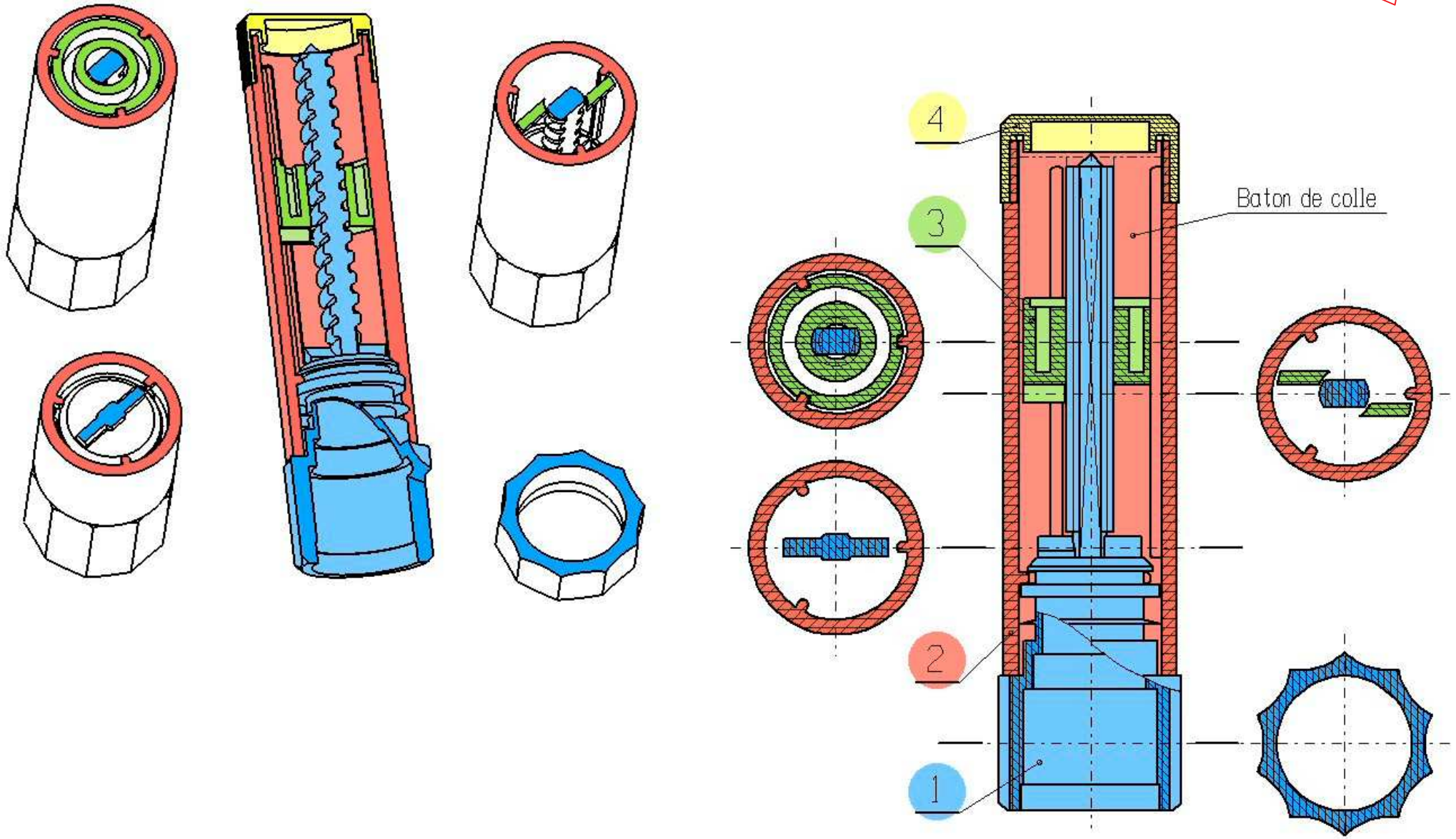

# Tube de colle

La transformation de mouvement est

réversible

irréversible

Indiquer le sens du filetage

A droite

A gauche

En conséquence, le symbole de la liaison hélicoïdale des schémas cinématiques est-il correct ?

oui

non



Fig. 5a



Fig. 5b

**CORRIGÉ**

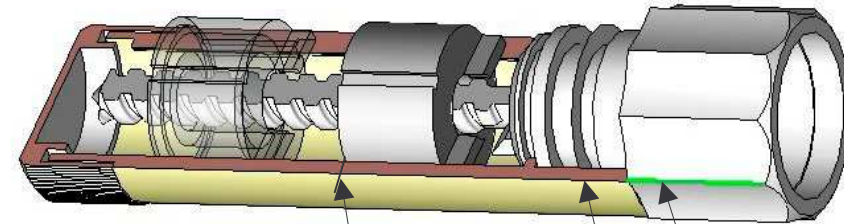
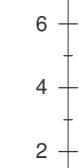

Fig. 8

Nb tour



X =

Ech : 1mm → 0,5 mm course

Entrée 1<sup>er</sup> filet

Entrée 2<sup>ème</sup> filet

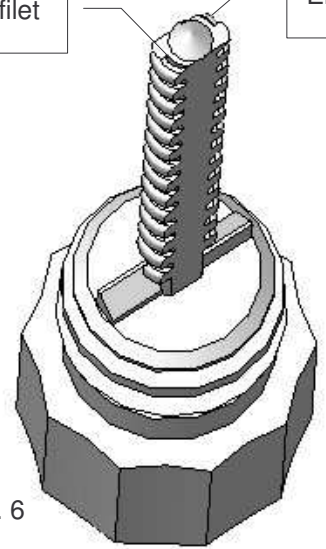

Fig. 6

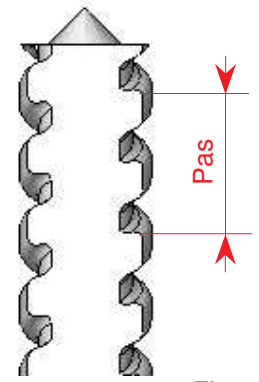

Fig. 7

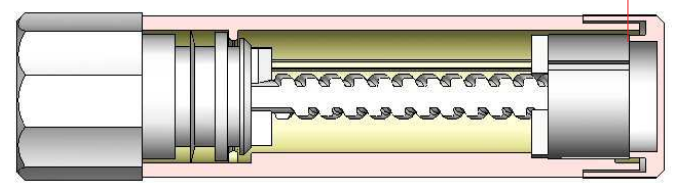
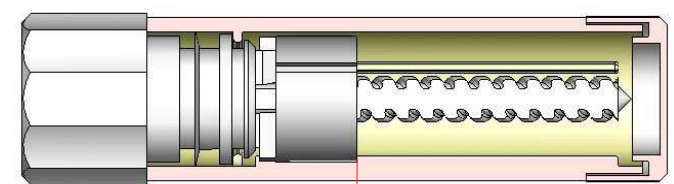
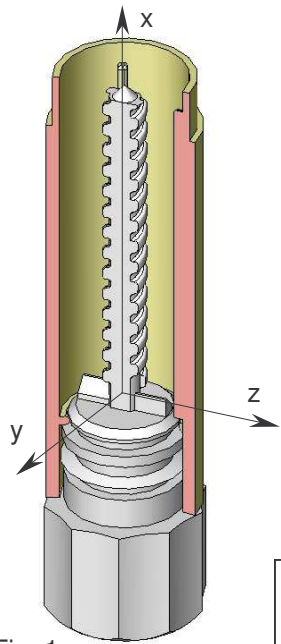

Fig. 9

# Tube de colle



Translation		Rotation	
Tx		Rx	
Ty		Ry	
Tz		Rz	

Type de la liaison entre le corps et la vis.

Fig. 1

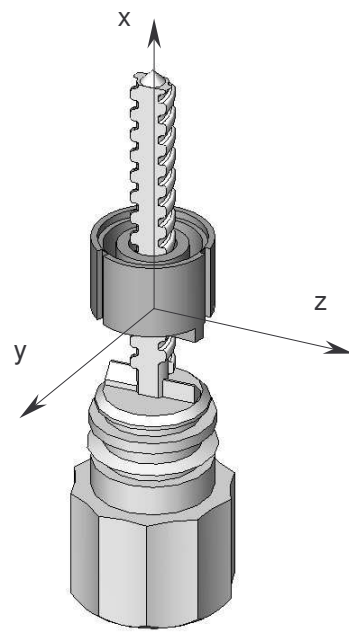

Translation		Rotation	
Tx		Rx	
Ty		Ry	
Tz		Rz	

Type de la liaison entre la vis et le coulisseau

Fig. 3

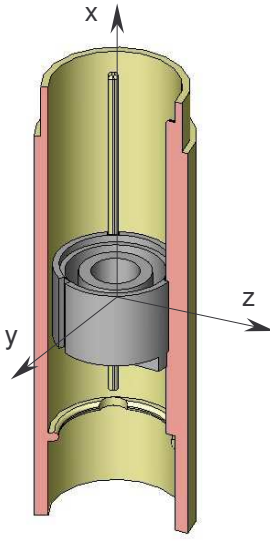

Translation		Rotation	
Tx		Rx	
Ty		Ry	
Tz		Rz	

Type de la liaison entre le corps et le coulisseau.

Fig. 2

**CORRIGÉ**

Légende :  
 0 : Degré supprimé ;  
 1 : Mvt possible

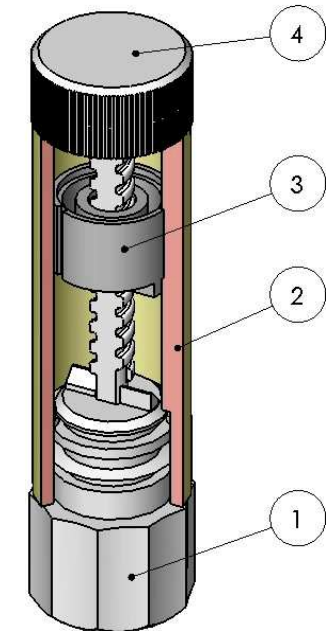



# Tube de colle

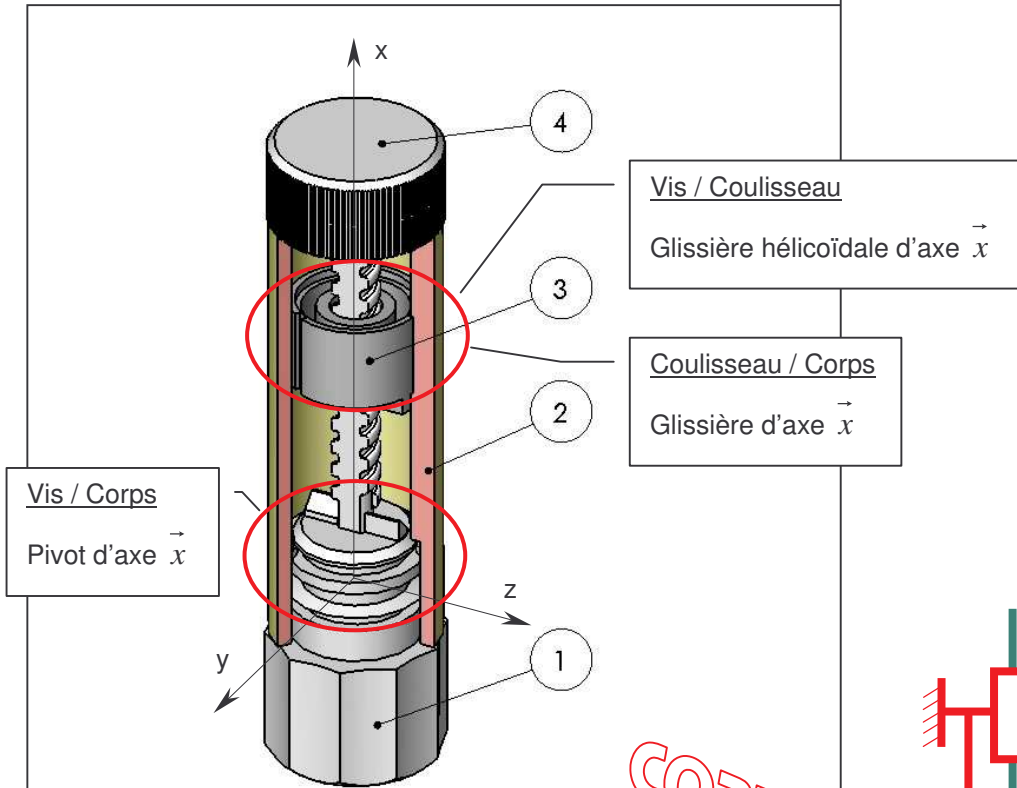

**CORRIGÉ**



Fig. 4a



Fig. 4b

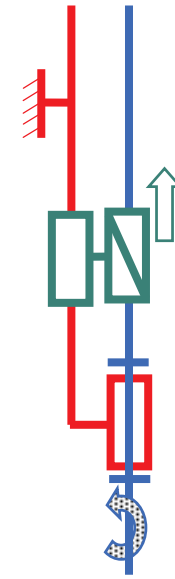

Fig. 4c

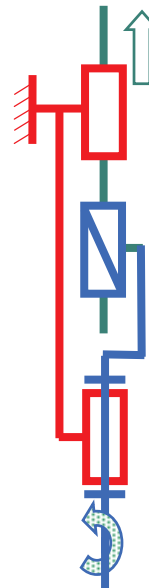

Fig. 4d

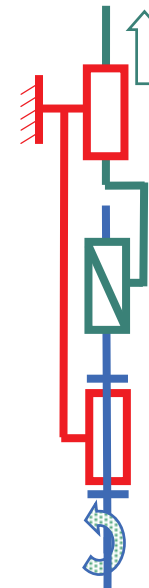

Fig. 4e

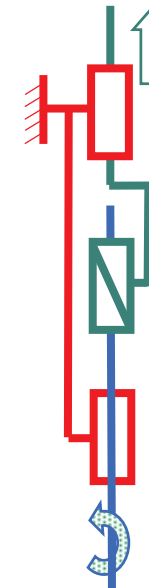

Fig. 4f

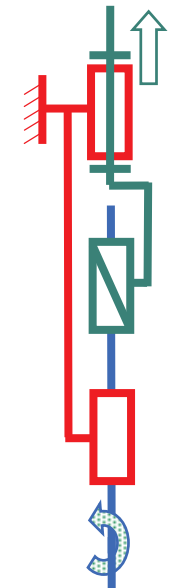

Fig. 4g